

MULTIFLAT



DESIGN FEATURES

FOUR POLISHING SPINDLES

FULLY PROGRAMMABLE

SIX MOVEABLE CLAMPING FEET

SIMPLE, EASY TO USE SOFTWARE

PNEUMATIC ROLLERS TO ASSIST WITH LOADING

OUTRIGGER TABLE TO SUPPORT LARGER PIECES

HANDLES SLABS UP TO 3200MM

Farnese Australia was founded in 2000 by the Farnese family, whose members have decades of combined professional experience and expertise in both the global stone industry and the local stone machinery manufacturing industry. We are the only designer and manufacturer of stone fabrication machinery in Australia and our machines have found homes throughout Australia, New Zealand, the United States, the United Kingdom, and Vietnam.

With over 20 years of experience in the stone industry, the team at Farnese have the experience it takes to design, install and maintain the equipment needed in your industry.

The **MULTIFLAT EDGE POLISHER** from Farnese shares it's DNA with our world renowned mitre saw, being built on the very same platform.

It is equipped with four automatic polishing spindles designed specifically for flat polishing.

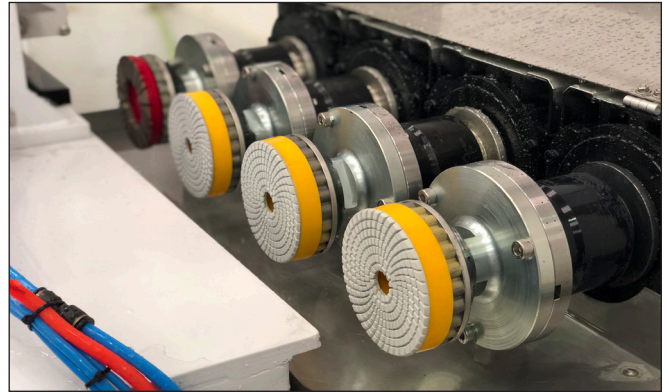

Like all Farnese machines, a simple, user friendly interface makes life easy for everyone.

All controls are within easy reach of the operator.

A simple PLC program controls the number of times the head moves back and forth during a cycle until the perfect polish is achieved.

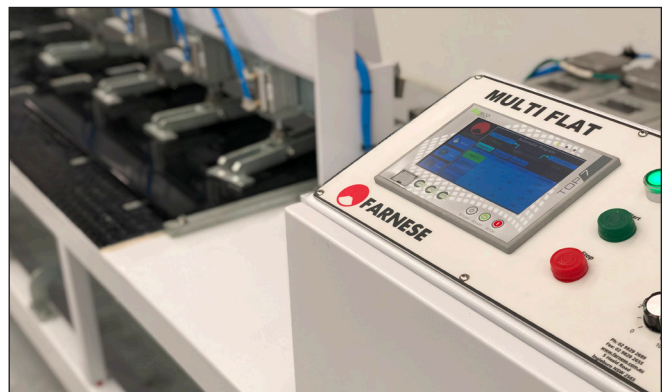

Each automatic spindle, whether it be fitted with a diamond or polishing pad, can be controlled individually from within the program. Operator designed programs can be stored in the PLC memory.

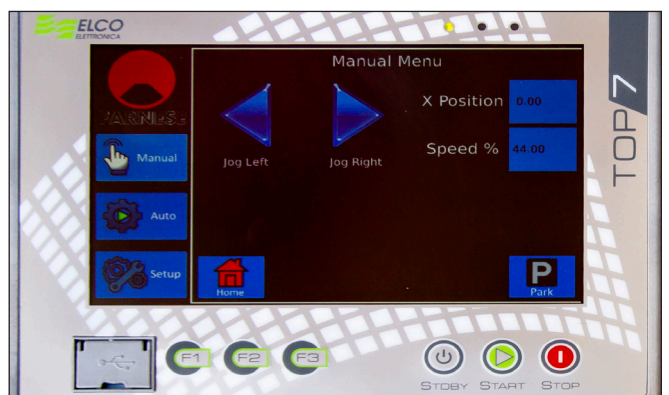

Water is fed through the centre of each spindle. Flow is controlled by an electric solenoid that turns on and off automatically with the spindle motor in order to conserve water.

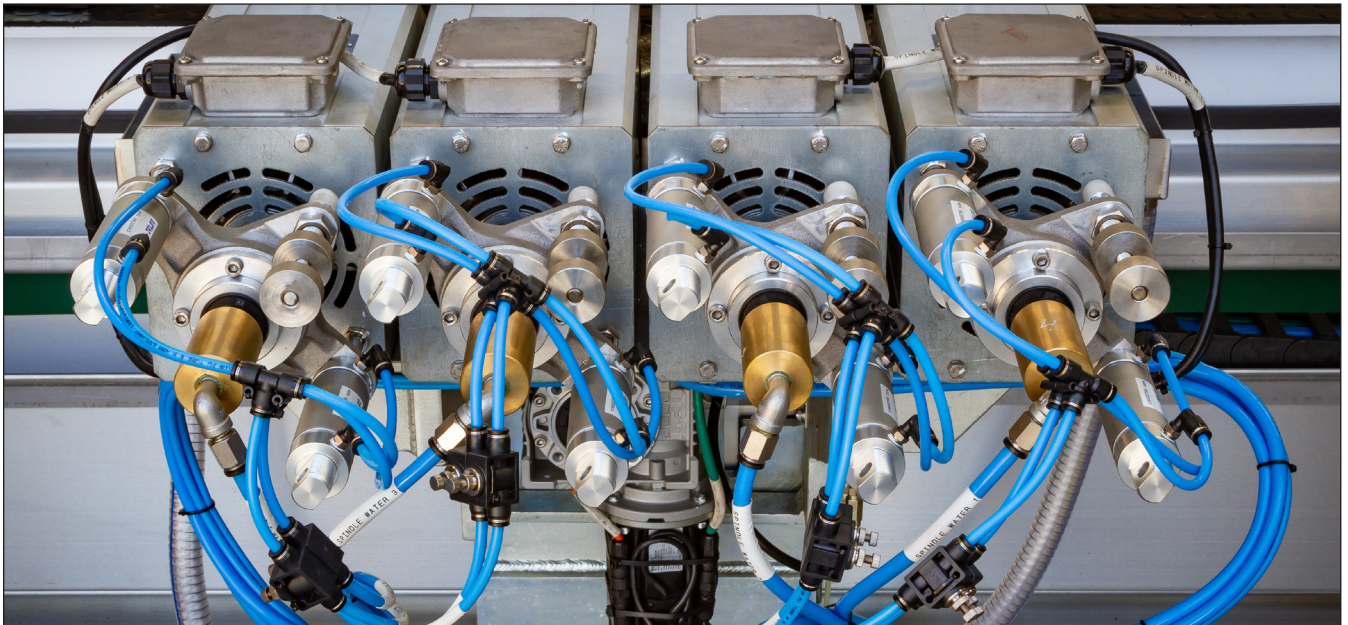

The **MULTIFLAT** is equipped with a series of pneumatic pop up rollers for ease of loading and unloading work pieces.

Once loaded, a series of six pneumatic clamping feet hold pieces firmly in place during the polishing process.

Each of these feet can be moved freely along the machine and positioned as required.

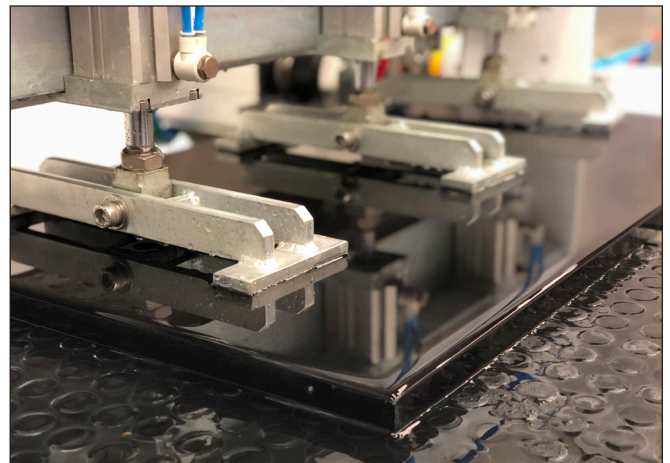

The rollers and the clamps are both controlled by the simple flick of a lever.

SAFETY FEATURE: Should an operator forget to lower the loading rollers prior to lowering the clamps, the machine will release the rollers when clamps are lowered.



The **MULTIFLAT** also features a pneumatically controlled stainless steel stop, ensuring that the work piece is positioned in the exact place for the polishing to proceed.

This stop can be raised and lowered with a button located on the main control panel.

Lubrication is taken care of via an automated system which can be programmed to deliver as necessary.

All components are easily accessible for service requirements.



The beauty of the **MULTIFLAT** is it's simplicity. Usually within a day, your machine will be installed and you'll have all the training you need to achieve a beautiful polish. However, should you need more assistance, rest assured that you'll receive the additional training required to make you an expert.

A 1 year warranty is offered a standard with the machine.

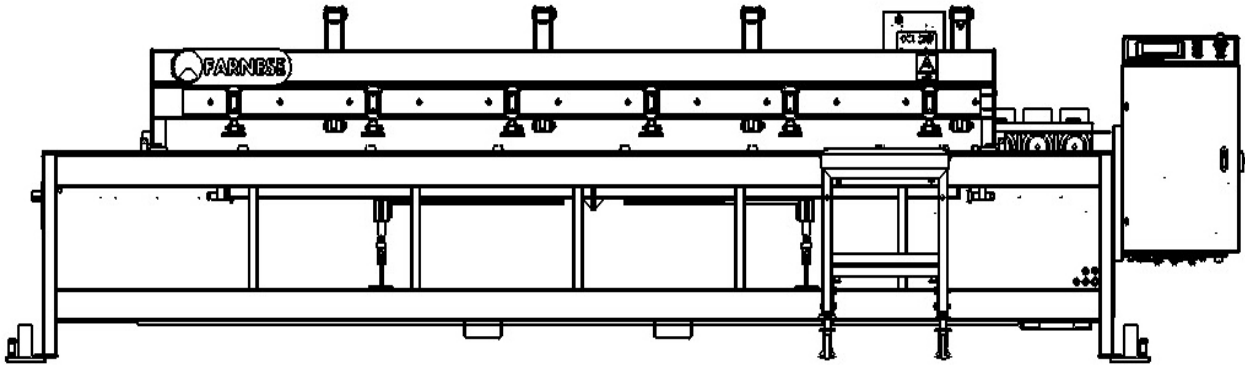

TECHNICAL SPECIFICATIONS

DIMENSIONS OF INSTALLED MACHINE	METRIC	IMPERIAL
LENGTH	5300 mm	208.7 in
WIDTH	1400 mm	55.1 in
HEIGHT	1400 mm	55.1 in
WEIGHT	1100 kg	2420 lb
ROLLER TABLE DIMENSIONS		
LENGTH	1600 mm	63.0 in
WIDTH	600 mm	23.6 in
HEIGHT	800 mm	31.5 in
FEATURES & FEEDS		
TABLE LENGTH	3400 mm	133.9 in
TABLE WIDTH	600 mm	23.6 in
X TRAVEL (CUTTING STROKE)	3300 mm	3.9 in
TOOL DIAMETER	100 mm	13.8 in
POLISHING SPEED	0 - 8m/min	1/4 - 2 in
THICKNESS RANGE	5 - 60 mm	2.0 in
MANUAL GREASING	YES	YES
MAIN SPINDLE POWER	1.7 kW	2.3 hp
TWO SPEED SPINDLE	1450-2000 rpm	1450-2000 rpm
POWER REQUIRED	400v 3ph 50Hz	208v 3ph 60Hz
	15A+ Neutral	28A
CONNECTIONS REQUIRED (SUPPLIED BY CUSTOMER) POWER, WATER, COMPRESSED AIR		
TOOLING CONSULT YOUR LOCAL FARNESE DEALER FOR ANY TOOLING REQUIRED		

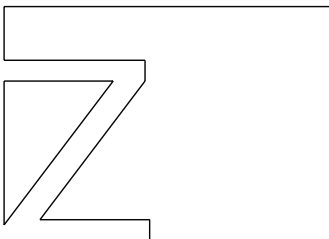

Owing to the constant updating of our designs, descriptions and technical data shown in our drawings and folders are not binding. Possible alterations deemed by the makers as convenient will be effected at any time without previous notice.

5 Heald Road, Ingleburn NSW 2565 Australia
 ABN: 47 057 462 629 • ACN: 057 462 629
 Phone: 1300 075 678 • www.farnese.com.au

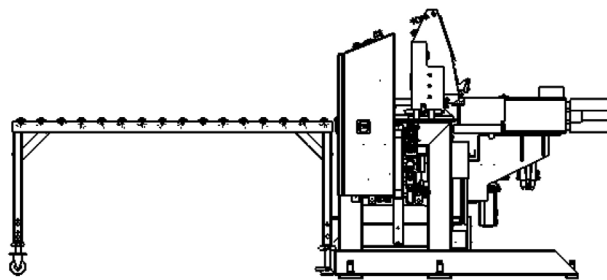
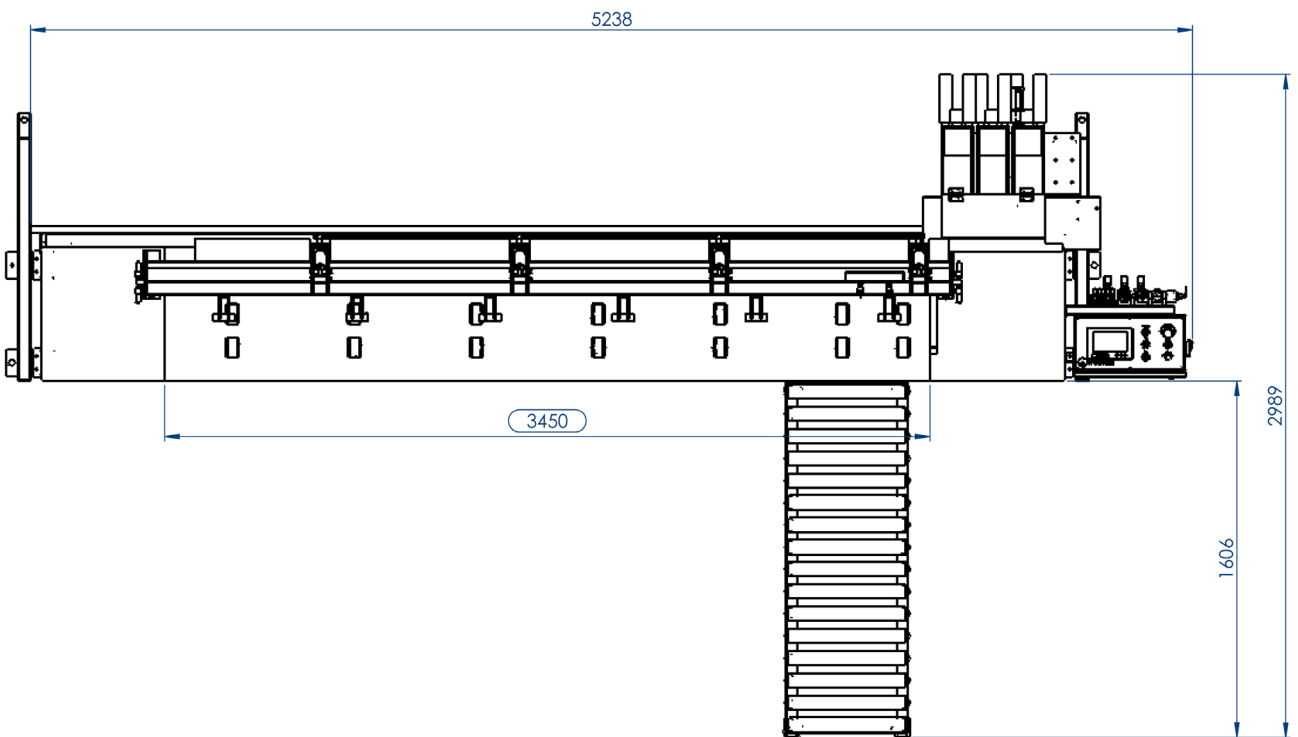
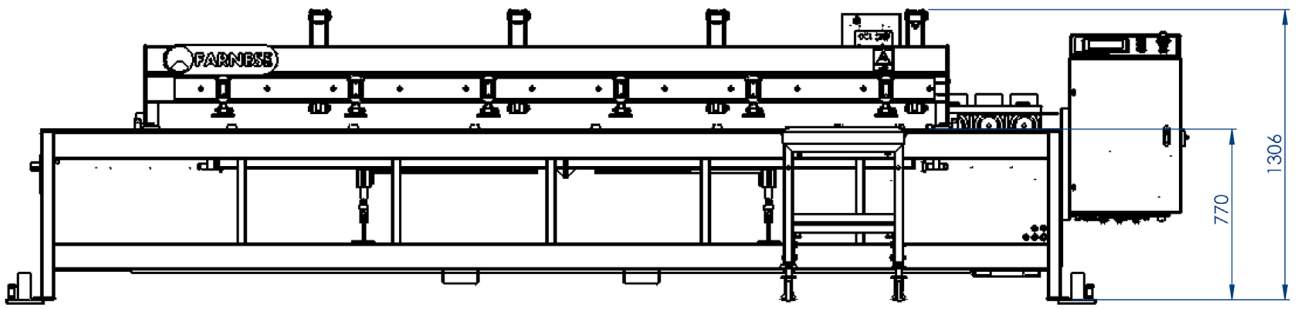



We Know That Support Is Important To You

Buying a new machine is a big commitment for anyone, and continued support throughout the life of that machine is vital.

Being an Australian company, Farnese carry a vast array of parts here in Australia to ensure that your machine always has the spares it needs. Enjoy peace of mind knowing that you'll be fully supported by Farnese and we'll always have you covered.

Farnese customers don't need to experience unnecessary machinery downtime waiting for remote assistance from other countries, as all the support and remote assistance is provided locally in Australia from our own qualified Technicians in Australian time.

With more Service Technicians in Australia than any of our competitors, our mission here at Farnese is to give you the best support in the industry. As we grow, we continue to recruit more and more qualified technicians, to further strengthen our position in the Stone Industry.

FARNESE AUSTRALIA PTY LTD 5 Heald Road, Ingleburn NSW 2565 Australia
ABN: 47 057 462 629 • ACN: 057 462 629
Phone: 1300 075 678 • www.farnese.com.au